

## SMALL 1 CA



### > BOLLITORE PER PRODUZIONE ACQUA SANITARIA CON SCAMBIATORE FISSO PER SOTTOCALDAIA DI PICCOLE DIMENSIONI

**GLASSTECH GT:** Bollitore a 1 serpentino in acciaio al carbonio, completo di protezione anodica, trattamento interno secondo normative DIN 4753-3 e UNI 10025. Isolamento: Poliuretano rigido iniettato 30 mm con finitura ABS.

### > TANK FOR SANITARY HOT WATER PRODUCTION WITH FIXED EXCHANGER FOR UNDER-BOILER OF SMALL DIMENSIONS

**GLASSTECH GT:** Water-heater made of high quality steel with 1 fixed pipe-coil, complete with anodic protection, inside treatment according to norm DIN 4753-3 and UNI 10025. Insulation: 30 mm Rigid polyurethane injected with ABS cover.

SMALL 1 CA		120	160
Volume utile Storage volume	l	115	150
Classificazione energetica Energy rating		C	C
Dispersione termica Standing loss	W	69	76
Bollitore isolamento poliuretano rigido iniettato 30 mm Foamed polyurethane layer 30 mm	ø mm	560	560
Altezza totale con isolamento Tot. height with insulation	mm	750	950
Altezza massima in raddrizzamento Diagonal size	mm	1050	1250
Scambiatore Heat exchanger	m <sup>2</sup>	0,8	1,1
Contenuto d'acqua del serpentino Pipe coil water capacity	l	3,9	5,0
Potenza assorbita Absorbed power	kW	27	34
Portata necessaria al serpentino Necessary capacity heat-exchanger	m <sup>3</sup> /h	1,2	1,5
Produzione acqua sanitaria 80/60°C-10/45°C (DIN 4708) Output sanitary water 80°/60°C - 10°/45°C (DIN 4708)	m <sup>3</sup> /h	0,6	0,8
Perdite di carico Pressure loss	mbar	240	480
Coefficiente (DIN 4708) Power code (DIN 4708)	NL	3,4	4,3
Peso a vuoto Weight empty	kg	54,5	65,5
Pressione massima del sanitario Max. working-pressure tank	bar		8
Pressione massima dello scambiatore Max. working-pressure heat exchanger	bar		10
Temperatura massima di esercizio del bollitore Max. working-temperature boiler	°C		95

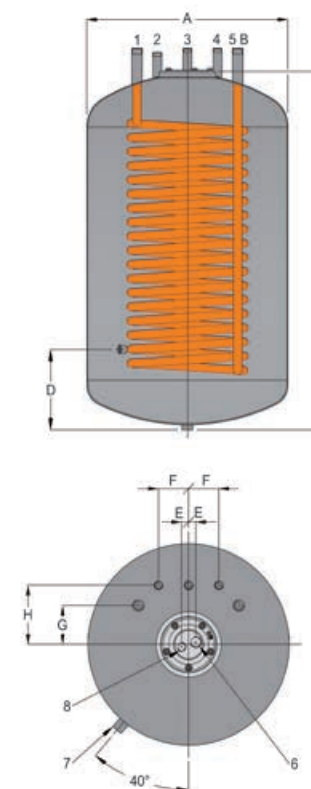

Mod. 120-160

N°	TIPO DI ATTACCO CONNECTOR TYPE	mod. 120-160
1.	Ritorno serpentino Water exchanger outlet	3/4" M
2.	Mandata acqua calda Hot water inlet	1/2" M
3.	Ricircolo Re-circulation	1/2" M
4.	Entrata acqua fredda Cold water inlet	1/2" M
5.	Mandata serpentino Water exchanger inlet	3/4" M
6.	Porta sonda Feelerweel	ø 10 mm
7.	Scarico Entleerung	1/2"
8.	Anodo Anode	3/4"

	Mod.	A	B	C	D	E	F	G	H
GLASSTECH GT	120	500	748	690	200	18	125	97	147
	160	500	948	890	200	18	125	97	147

Mod.	POLIURETANO RIGIDO INIETTATO 30 mm FOAMED POLYURETHANE LAYER 30 mm
1 CA GT	COD.

120	NS1100094
160	NS1100095